

MODEL 715

1 1/2" (MINI) PITCH CHIP CONVEYOR

This compact but rugged conveyor is the ideal choice for handling very small parts, stampings, scrap, chips and turnings. Its condensed size also allows it to fit into tight spaces to small for a standard 2 1/2' pitch machine.

1700 Division Street, New London, WI 54961

Phone: (920) 982-4030; Fax: (920) 982-6800

Website: www.nleco.com

Widths: 4" – 18" (Custom Widths Available)

Lengths: 3' – 20' (Infeed = 12" / Discharge = 18")

Curves: 30°, 45° and 60°

Standard Speed: 30 FPM

Standard Motor: 1/2 HP 230/460/3/60 TEFC

Standard Drive: Top Mount, Right Side

Frame: 4 1/8" Deep at Infeed; 6-5/8" Deep lower curve thru discharge x 14 Gauge

Bearings: Grease Sealed at Discharge; Press In Bronze Bushings at Infeed

Sprockets: 10 Tooth x 4.854" Pitch Diameter

Belt: 1 1/2" Pitch Hinged Steel Belt, One Piece Conventional 14 Gauge Apron, with 5/8" high cleats on 12" Centers, 12 Gauge x 3/4" high radial side wings, 7/8" x 1/2" wide Flat Face Rollers, 12 Gauge Outside Sidebars

Note: Available in conventional style belt only

CHAIN WIDTH:	4"	6"	8"	10"	12"	18"
FRAME WIDTH:	7 1/2"	9 1/2"	11 1/2"	13 1/2"	15 1/2"	21 1/2"

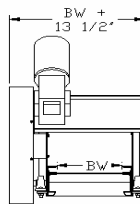
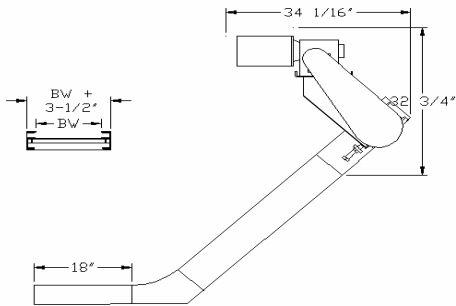

45° TOP MOUNT DRIVE

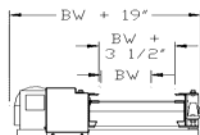
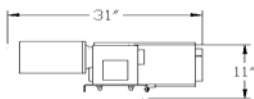

SIDE MOUNT DRIVE

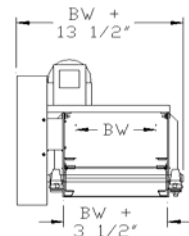
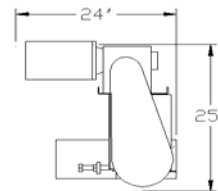

TOP MOUNT DRIVE